

T6 SERIES MANUAL KNOT SPLICING SYSTEM CONTINUOUS RUNNING ELASTIC THREAD FEED

The Manual Knot Splicing System was developed to achieve a reliable elastic thread feeding and elongation control system with continuous running thread feed. The system maintains accurate and consistent elongation control, resulting in optimum production efficiencies, thread utilization value, and product performance.

The knot splicing system provides a manual, assisted knot splice of an individual standby thread to an active running thread. The splice allows continuous thread feed without stopping the production line. Thread waste at the spool change is very low, as the knot splice can be initiated when the running spool has the lowest practical amount of thread remaining.

The manual knot splicing system combines two proven operational systems: a splicing tube fixture that is integrated with a modified AccraTec T-Series unwind system.

- The splicing tube fixture is integrated to align an individual splicing tube with each thread and allow the thread to run through the tube without contact. A slot the length of the tube allows placement of the thread within the tube. The splicing tube provides a surface to manually wrap the new standby thread around the running thread and form an overhand splice knot without contacting the running thread.
- The standard AccraTec T-Series unwind system is modified to include a minimum of one extra spool position for placement of a standby spool. The thread guiding is modified to allow placement of a thread in any thread path position from any spool position. There is a lift device at each position to hold the standby spool in a nonrotating position above the spool drive rolls.

The splice is manually initiated by slipping the knot off the splice tube to contact the running thread while simultaneously pushing a foot switch. The foot switch activates a pneumatic valve, which releases the spool lift device, allowing the spool to contact the drive rolls and begin feeding thread. The splice results from the standby thread knot contacting the running thread. In addition, the running thread creates a twisting force that entangles the running and standby threads further securing the splice. The twisting also controls the non-elongated thread tail as the splice moves through the thread path to placement in the product.

Optional Manual Knot Splice assemblies:

- Alternative thread feeding and spool capacities to optimize operation and integration of the Knot Splice System with a production line.
- Standard DC drive or optional AC vector drive.
- Analog or Digital master speed reference.
- Integrated thread break detection

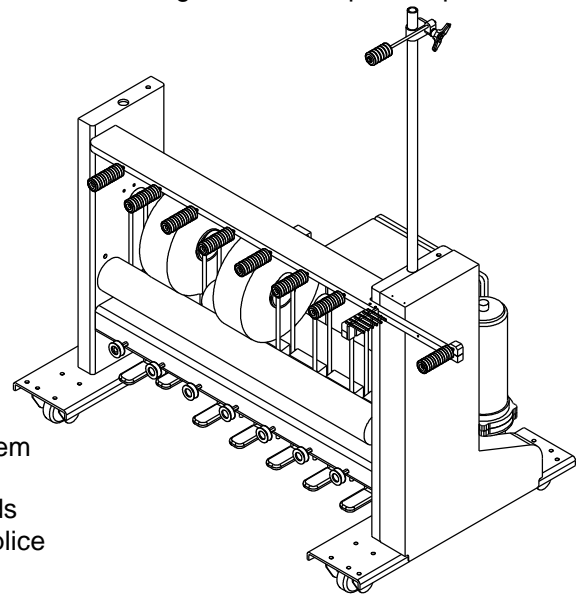

T6 Manual Knot Splicing System
(7) Spool Positions
(6) Positions Feeding Threads
(1) Position Standing By For Splice

AccraTec will provide a quotation for standard or alternative idler assemblies upon request.

Email request to Daniel J. Heaney at dan@accratec.com
Or contact via the information below